

Flex PCBs Explained

From Materials to Applications

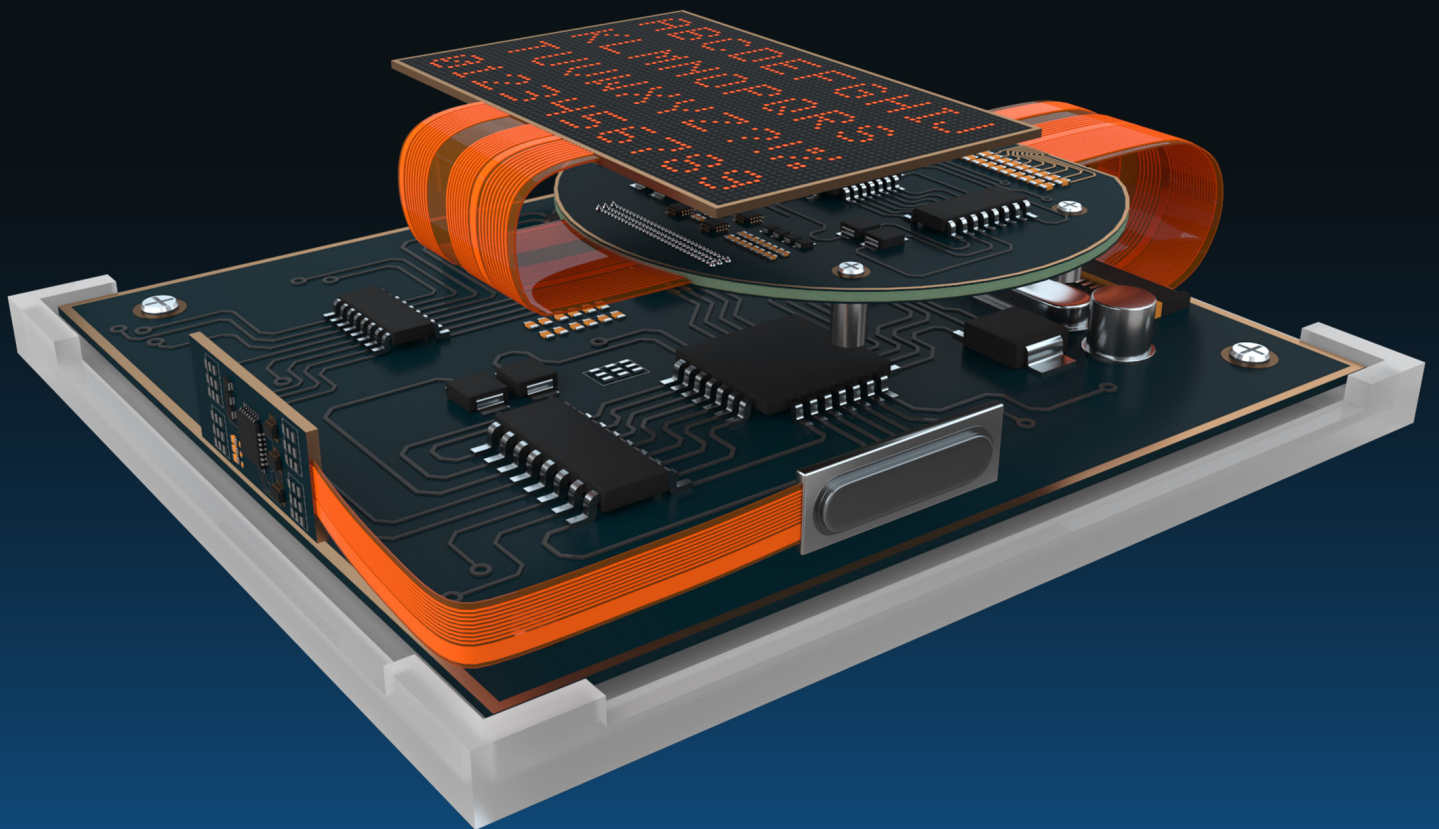

Contents

Designing the Impossible: How Flex PCBs Revolutionized the Electronics Industry.....	3
Introduction: Why Care About Flex PCBs?.....	4
What Are Flex PCBs?	4
Rigid PCBs.....	4
Flex PCBs	6
The Benefits of Flex PCBs.....	8
Flex PCB Materials and Challenges.....	9
Materials	9
Coverlay.....	9
Flex Substrates	10
Stiffeners.....	10
Adhesives.....	10
Conductors.....	10
Plating.....	10
Challenges	10
Limited Bending Cycles	10
Minimum Bend Radius:	11
Material Considerations	12
Stress and Strain on Circuitry.....	12
Component Placement.....	12
Overcoming Challenges.....	12
Design for Flexibility	12
Material Selection	12
Manufacturing Considerations.....	13
When Should You Use Flex Instead of Rigid?	13
Applications of Flex PCBs.....	13
Wearable devices	13
Handheld electronics	15
Automotive electronics.....	16
Medical equipment.....	17
Aerospace and defense.....	17
The Future of Flex PCB Design Data	18
Conclusion.....	18
Appendix (Useful Information)	18
Design Standards for Rigid-Flex PCBs	18
Example Rigid-Flex Stack-Ups.....	18
List of Terms and Materials.....	21
Additional Resources.....	21

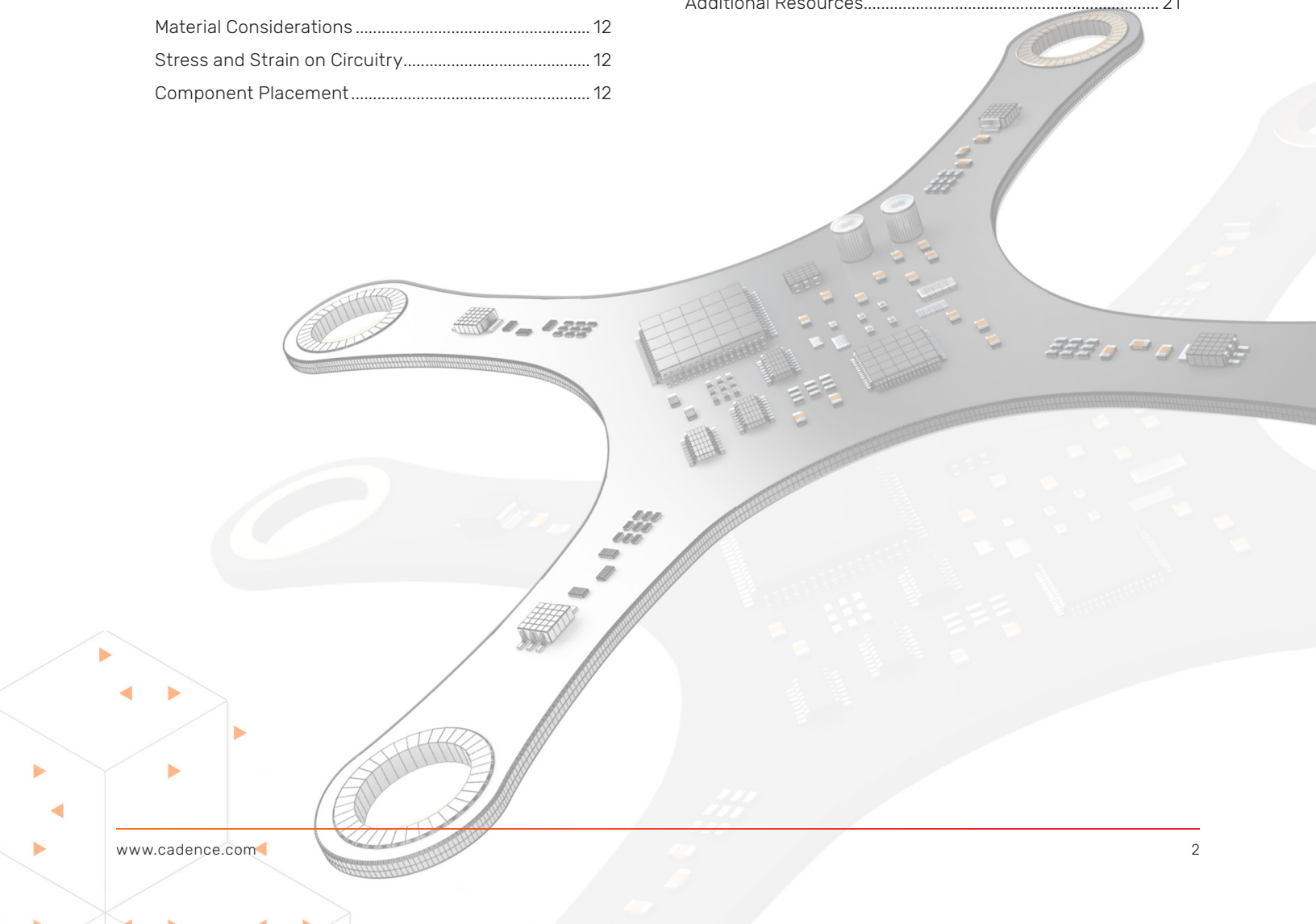

Designing the Impossible: How Flex PCBs Revolutionized the Electronics Industry

Long before the smartphone industry was revolutionized, flexible printed circuit boards (flex PCBs) were quietly making waves across various sectors. Originally developed in the 1950s for military and aerospace applications, these unsung heroes of electronics offered a solution to some of the most demanding technological needs – flexibility, light weight, and resilience.

As the decades ticked by, these circuit boards became increasingly integral to advancing consumer electronics, medical technology, and even automotive systems. Their ability to bend, twist, and flex opened up new realms of design possibilities, making the once impossible now achievable.

Then, in 2007, the release of the iPhone showcased flex PCBs' potential to a broader public. Featuring them in a compact, sleek device as envisioned by the visionary Steve Jobs, this marked a pivotal moment for the technology, highlighting its critical role in modern electronics design.

The story of flex PCBs is about necessity driving invention. As the demands on electronic devices grew, engineers found themselves increasingly constrained by the rigid, traditional circuit boards. They needed to innovate, to push the boundaries of what was physically possible, and that's exactly what they did.

In this comprehensive guide, you'll embark on a journey of discovery, exploring how flex PCBs have transformed industries, enabled new product categories, and changed the way we approach device design.

Whether you're a seasoned PCB designer or a newcomer to the field, you'll find invaluable insights and step-by-step instructions to leverage the full potential of this revolutionary technology.

So, get ready to unlock the future of electronics. The path ahead may bend, twist, and flex, but with flex PCBs in your arsenal, the impossible is well within reach.

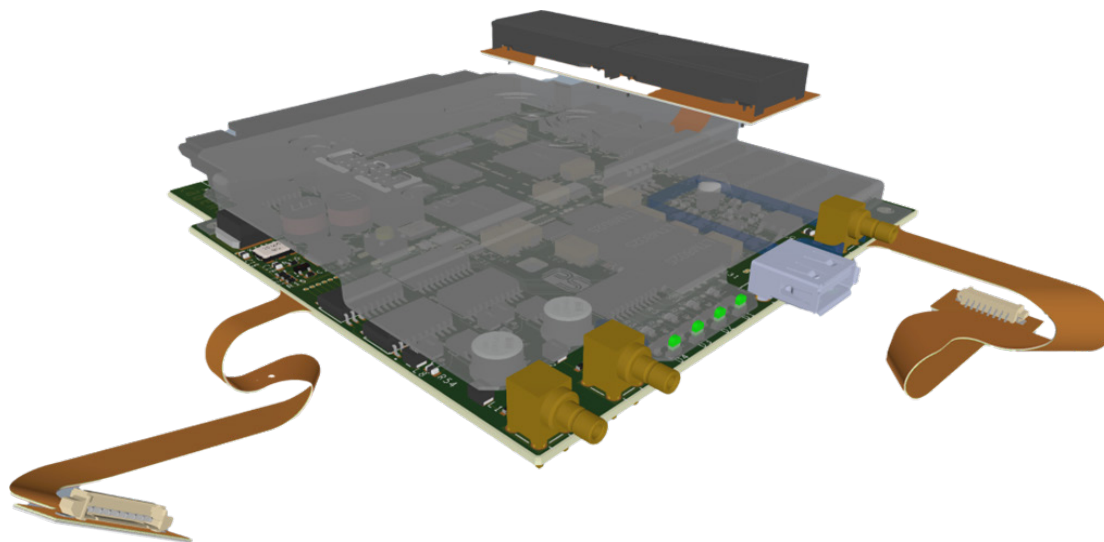

3D View of Cadence PCB from OrCAD X

Introduction: Why Care About Flex PCBs?

In today's fast-paced, technology-driven world, the demand for compact, efficient, and versatile electronic devices has never been higher.

As product designs become increasingly sophisticated, engineers are constantly challenged to find innovative solutions that push the boundaries of what's possible. This is where flexible printed circuit boards (flex PCBs) emerge as a game-changer.

Flex PCBs offer a unique set of advantages that make them an indispensable tool in the modern electronics industry. Unlike their rigid counterparts, flex circuits can bend, flex, and twist, allowing seamless integration into compact and complex device designs.

This flexibility is enabled by using flexible plastic films like polyimide as the base non-conducting material between copper layers, instead of the rigid fiberglass prepreg and core materials used in standard PCBs.

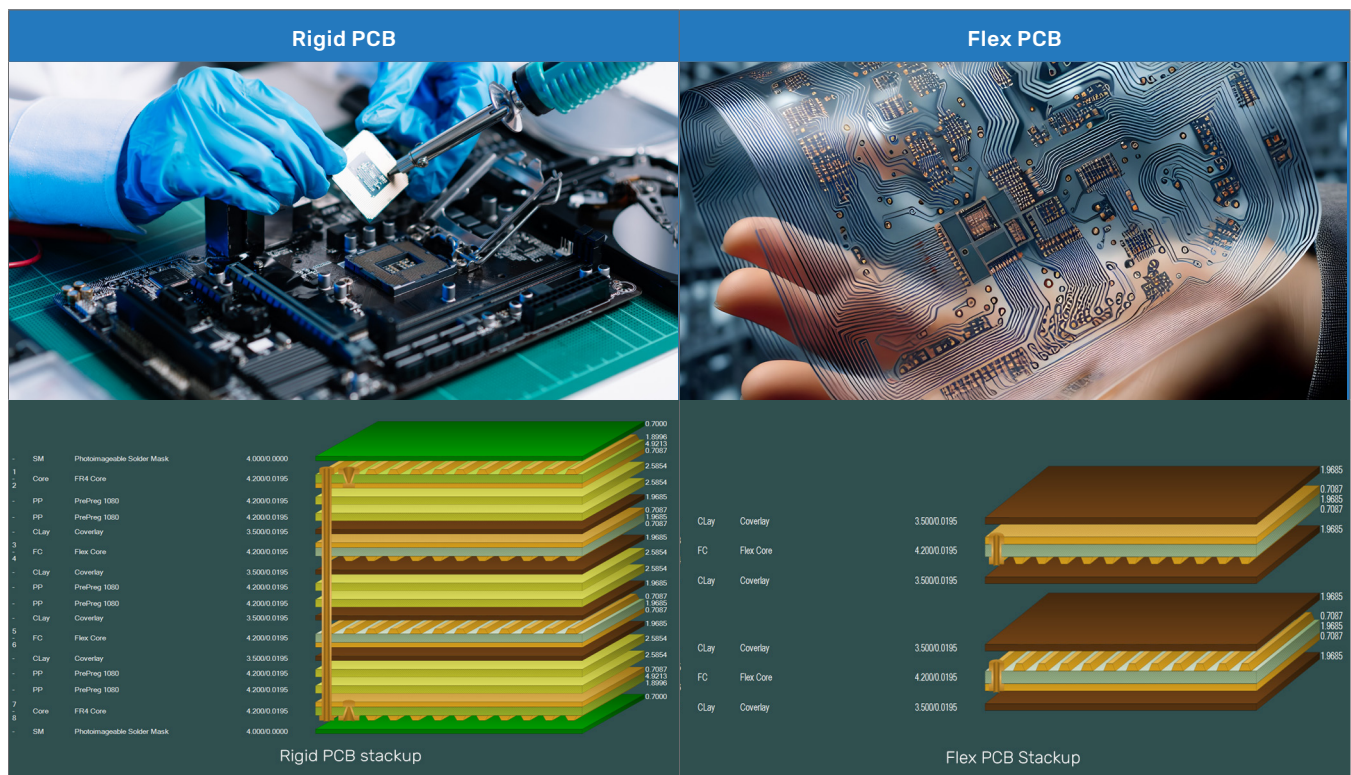

What Are Flex PCBs?

So what exactly are flex PCBs made of? To understand flex PCBs, let's discuss rigid PCBs and then the difference between them and flex.

Rigid PCBs

Rigid PCBs are the most common type of printed circuit board. They are made by taking sheets of fiberglass cloth and soaking them in an epoxy resin.

This creates a sturdy material that from here on we will call a substrate. This substrate is made of what looks like tightly woven fibers embedded in a hardened gel-like material.

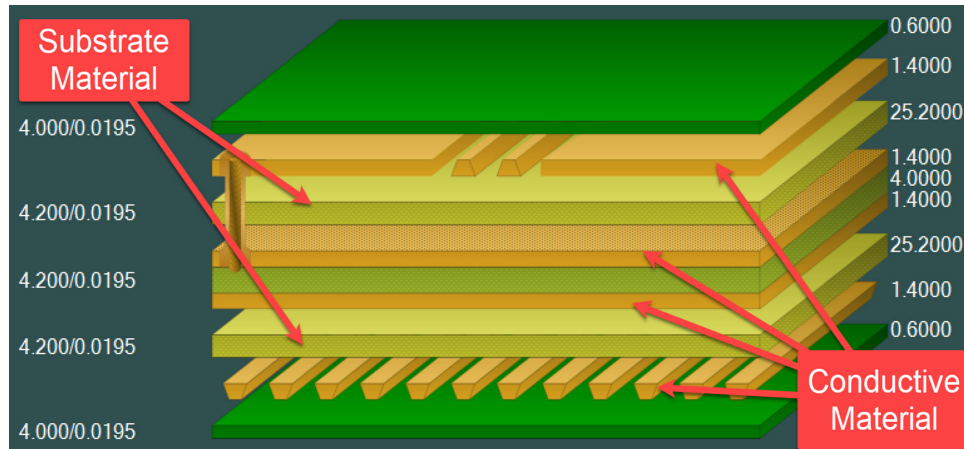

Close-up of Substrate material or within rigid stackup

Sheets of copper foil, about as thin as a human hair, are then bonded to one or both sides of the substrate.



Strands of Human Hair

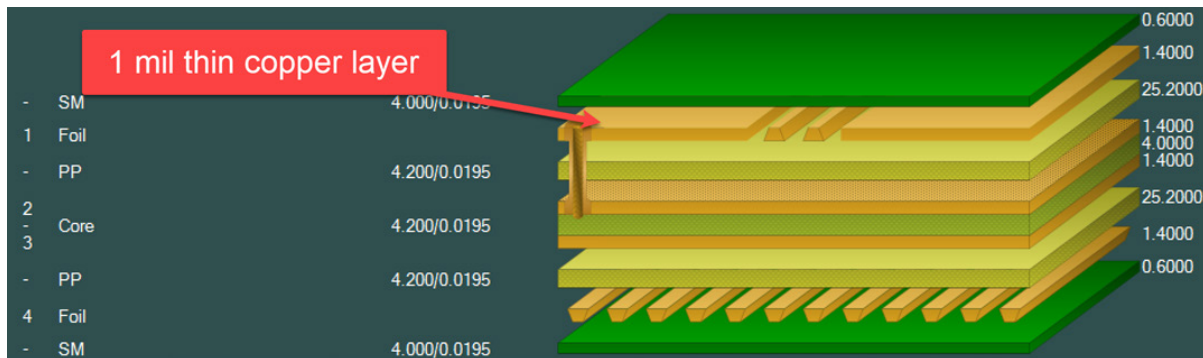

Sheet of 1/2 oz. copper thickness shown to scale/comparison with strands of hair

This copper-clad substrate can be repeatedly etched and plated to build up multiple layers of circuitry, creating a rigid board around (60 mils) 1-2 mm thick



PCB Stackup showing standard thickness of a 4-layer PCB

Flex PCBs

Flex PCBs work very differently. Instead of the woven fiberglass substrate, they use extremely thin (often under 3.9 mils / 0.1 mm) flexible plastic films (made of polyimide or polyester) as the base layer.



Real thicknesses of substrate layers

Rather than sheets of copper foil, rolled annealed copper is bonded directly to the flexible plastic substrate using an adhesive.

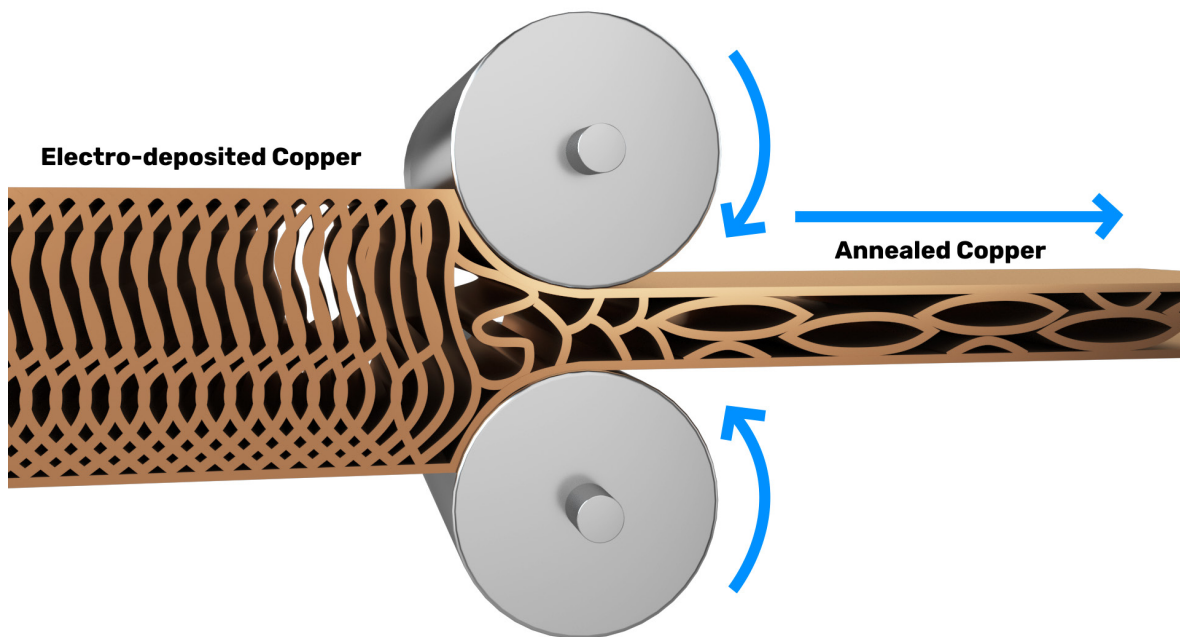

Rolled annealed copper

This allows the copper to bend and flex with the plastic film substrate underneath.

Additional layers can be added by building up more plastic film and copper in an alternating stack.

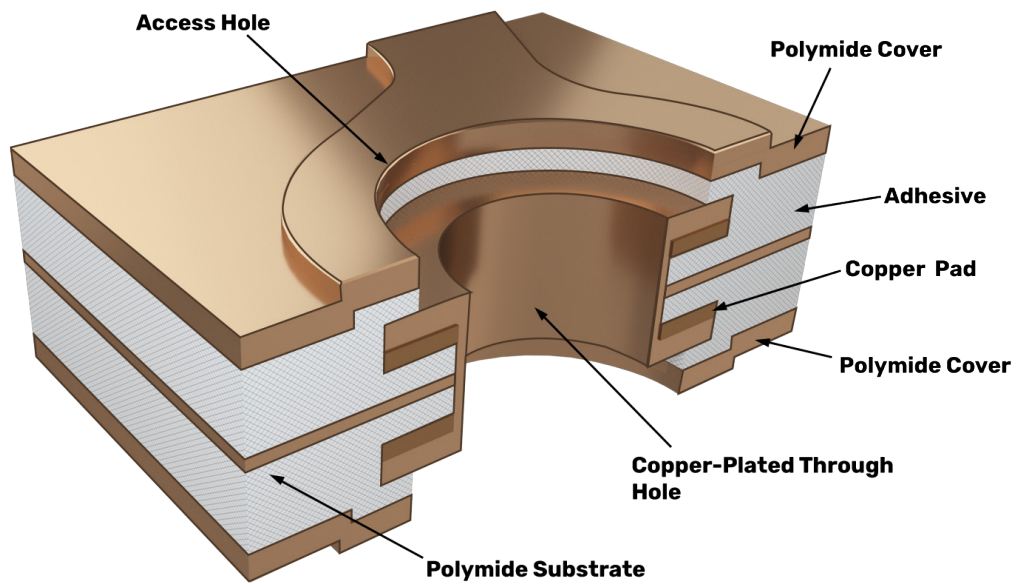

Flex PCB

The result is a flexible, bendable circuit that can twist, fold, and flex into tight 3D spaces - unlike the flat, rigid construction of standard PCBs.

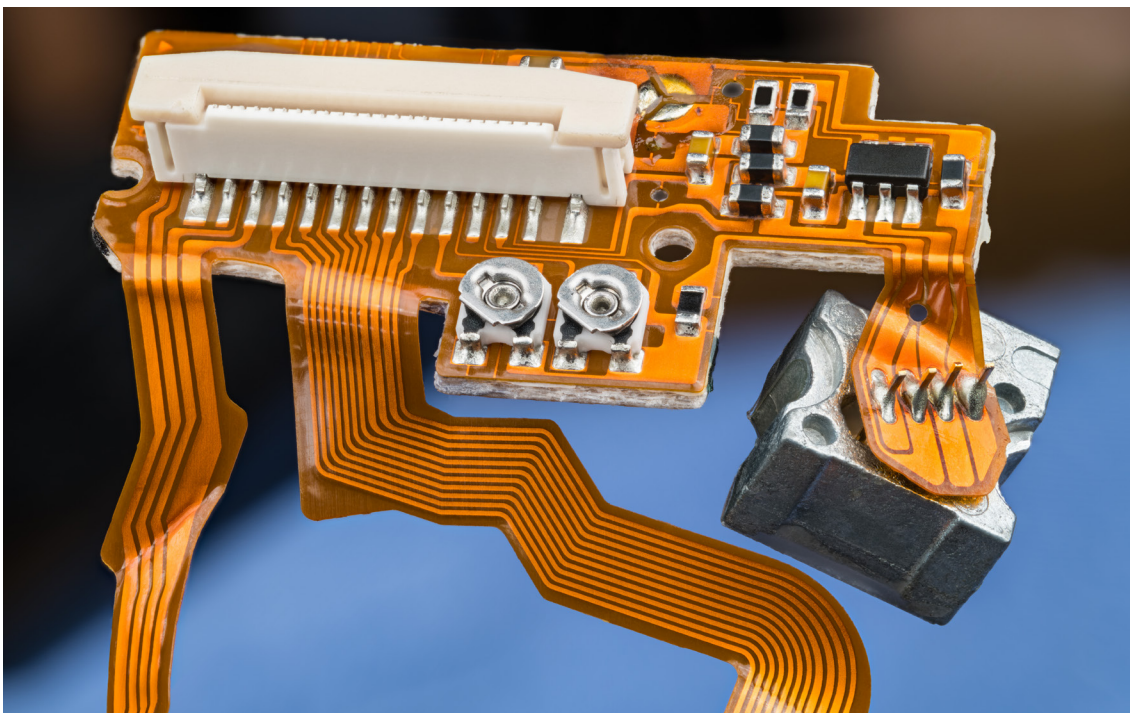

Orange printed circuit board with flex ribbon cables

The rigid construction gives standard PCBs more structural integrity but limits the shapes and sizes they can fit into. Flex PCBs sacrifice some rigidity for the ability to contort into virtually any 3D shape required, enabling compact electronics packaging. This makes flex circuits essential for modern slim devices like laptops, smartphones, wearables and more.

This flexibility opens up a world of possibilities, enabling engineers to create products that are smaller, lighter, and more durable than ever before.

The Benefits of Flex PCBs

Flex PCBs offer a range of benefits that make them a compelling choice for modern electronic designs:

- ▶ **Space and weight savings:** Flex circuits can be routed, bent, and folded to fit into tight spaces, allowing for more compact and lightweight device designs.

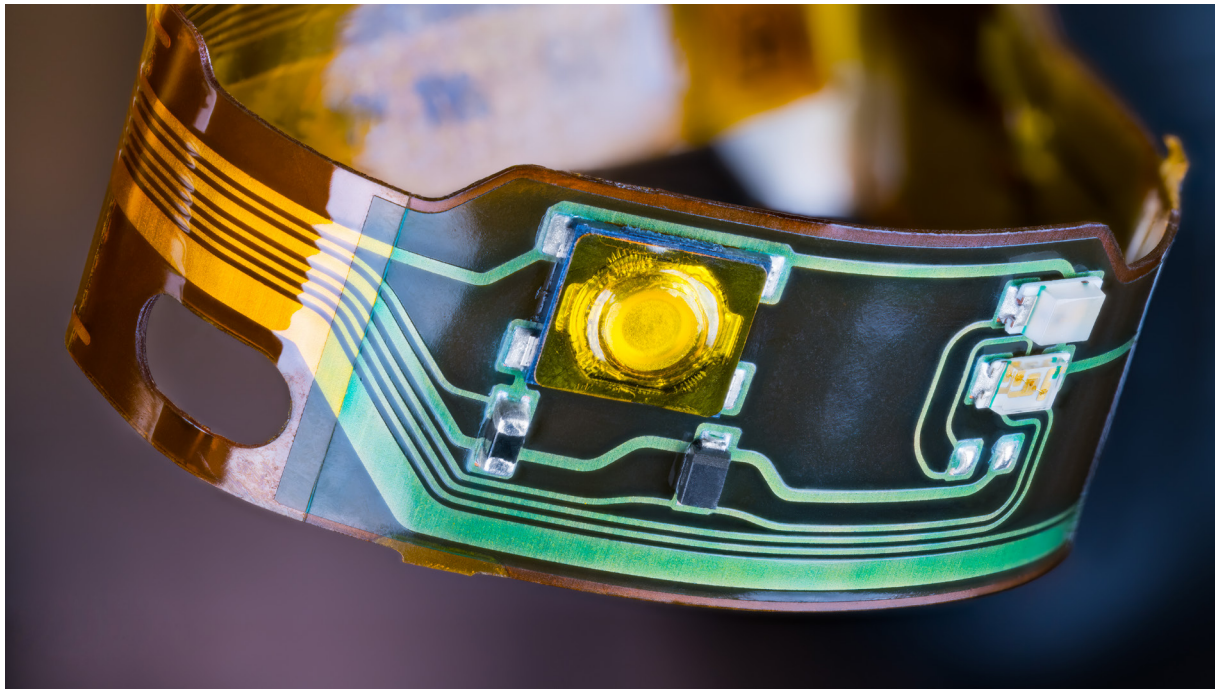

Small Flex PCB

- ▶ **Improved reliability:** Flex PCBs are better able to withstand bending, twisting, and vibration, making them more durable and reliable than their rigid counterparts. For example, this makes them good for military applications and extreme environments.
- ▶ **Design flexibility:** The ability to shape and form flex circuits opens up new possibilities for product design, enabling innovative and ergonomic form factors. We're no longer limited by what products can be created based on the shape of a rigid PCB. Imagination comes more into play and a case in point of this would be wireless headphones.
- ▶ **Simplified assembly:** Flex circuits can eliminate the need for cables and connectors, streamlining the assembly process and reducing the risk of wiring errors. Take any camera or cell phone for example - having less hassle with prototypes that have high pin counts where crossed connections can fry components.
- ▶ **Signal integrity:** Flex PCBs can be designed with controlled impedance and shielding, providing improved signal integrity and performance for high-speed, high-frequency applications. The polyimide material typically used in flex PCBs has a more consistent dielectric constant, compared to standard rigid PCB substrates. Now you have more consistent signal integrity performance.

Flex PCB Materials and Challenges

Materials

Choosing the right material is highly dependent on the requirements of the design. There is no 'favorite stack-up' when it comes to flex PCBs, because some areas may need more or less flexibility, may need no flexing or lots of flexing. In short, every flex stack-up is performed on a case-by-case basis, so understanding what materials you have available is the most important part of choosing the right stack-up for your application. Speak with your manufacturer on specifics, but here is a list of the materials, and when and why you would use them using a systematic approach for any application.

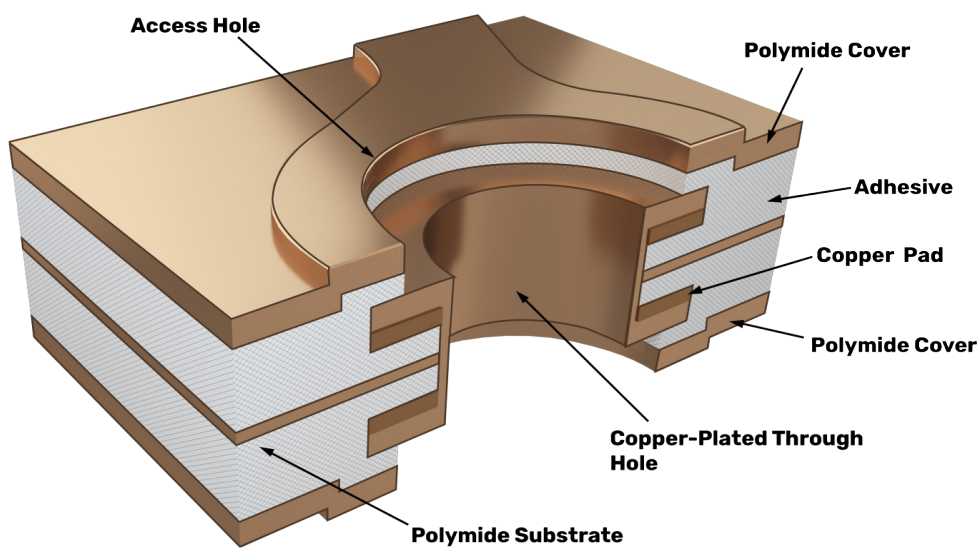

Double-sided flex circuit board

Coverlay

Typically 1–2 mils thick, this protects your conductive materials and essentially replaces the solder mask you'd find on a rigid PCB. Soldermask is not quite as flexible and can crack (however, some soldermasks can still be found in specific flex applications if needed). A common coverlay material is LPI (liquid photoimageable), which offers good flexibility and conformability during manufacturing.

Polyimide: Offers excellent flexibility, high-temperature resistance, and good chemical resistance.

LCP (Liquid Crystal Polymer): Provides superior dimensional stability and moisture resistance compared to polyimide.

Colors: Coverlays can carry various colors. Black is a popular coverlay (or stiffener or shield, depending on the designer's choice) color choice in Apple consumer electronic products.

Flex Substrates

Coverlay counts as a flex substrate, but in this case of flex PCBs, we're considering internal layers as well. These layers are typically made from flexible polymeric films.

Polyimide (PI): Offers excellent flexibility, high-temperature resistance, and good chemical resistance. Suitable for demanding applications and can be used as a mild stiffener (compared to more expensive stiffeners shown later). Adhesive-less polyimide is preferred for high-speed applications due to its consistent electrical properties.

Polyester (PET): Provides good flexibility and dimensional stability at a lower cost than polyimide. However, consider the quality and how often the PCB will need to flex or bend. Polyimide is usually a safe bet for better durability.

PEN (Polyethylene Naphthalate): More dimensionally stable than PET, with a higher temperature rating.

Stiffeners

Since the flexible substrates above are not rigid, we need to stiffen some areas to hold components. The materials used are called stiffeners and have a good variety of selections:

Polyimide (PI): Extra layers of PI can provide a cheaper stiffening solution. However, PI is still quite flexible, so tougher materials may be required for more stiffness.

Fiber-glass with Epoxy-resin (FR4): This is the same material found in rigid PCBs. It is more rigid than your standard PI.

Stainless steel, Aluminum, etc.: Depending on the manufacturer, you can have other stiffening materials. Speak with the manufacturer about your requirements and after performing deep research, you will know which material is suitable for your application. These metal stiffeners are typically more expensive than FR4 or PI.

Adhesives

Used to connect your flex material to copper and stiffeners and other material layers as needed.

Acrylic: Commonly used for bonding flex layers and rigid sections. Offers good adhesion and flexibility.

Epoxy: Provides higher temperature resistance and better chemical resistance than acrylic.

Conductors

Copper: Most commonly used conductor and typical thicknesses range from $\frac{1}{3}$ to $\frac{1}{2}$ oz. You want to stay in the 3 mil trace and spacing range for flex material in general. However, it's typical to have flex PCBs in the 2 mil trace width and space range. Note that flex copper is often rolled annealed copper. It's smoothed and manipulated to be more flexible to withstand various bends, unlike typical copper found in rigid PCBs. However, that makes the copper smoother, thus requiring better adhesive selection. We also have increased manual processes and thermal bonding required to combine the layers.

Plating

Newer designers may not be aware that plating of 1-2 mils is performed on standard PCBs. In flex PCBs, you don't have typical mass plating. You would define the extra plating as needed for vias and specific sections of the PCB.

Now that we have a thorough understanding of the materials, their challenges and guidelines on how to handle them, let's discuss when we should work with these challenges vs standard rigid PCB problems.

Challenges

Limited Bending Cycles

Static vs. Dynamic Flex PCBs: There are two main categories of flex PCBs: static and dynamic. Static flex boards are designed to bend only a limited number of times (typically less than 100) during assembly. Dynamic flex boards can withstand repeated bending cycles (tens of thousands) but require a more robust design.

Minimum Bend Radius:

When thinking about flex PCBs, the first question you may have in mind is 'how much bend is acceptable?'. First we need to understand the concept of a bend radius and why you want it to be large as opposed to small. Designing for a proper bend radius is crucial. A tighter bend radius can cause the copper circuit to fracture and lead to circuit failure.

Ensure that the bend radius meets the minimum requirements specified by the flex material manufacturer and IPC-2223 to avoid stress concentrations and ensure reliable flexing. Note that the tighter a PCB flexes and bends, the smaller its bend radius.

In general we want as soft a bend as possible to extend the life of our flex material. This software bend translates to a larger bend radius. As your radius gets smaller, the bend gets tighter and the copper in the flex material is more prone to break over repeated bending. We therefore want to have a radius no smaller than a certain amount. This is called the minimum bend radius. That minimum bend is:

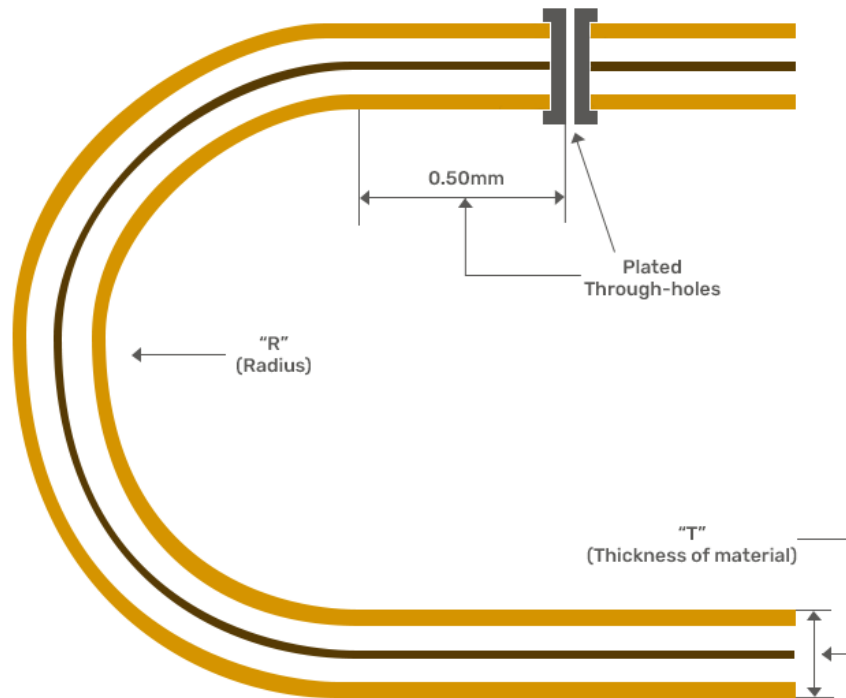

Bend radius calculation
i. Calculation of a recommended/minimum bend radius

Number of Layers (Copper)	Recommended Bend Radius (Go no smaller than this radius to avoid bend damage) mils
1- to 2- layer flex PCB	Thickness of Flex Material × 10
3-layer flex PCB	Thickness of Flex Material × (15-20)
Multi-layer (4 or more) flex PCB	Thickness of Flex Material × (25-30)

Source: MadPCB.com

Material Considerations

Copper Type and Grain Orientation: Rolled annealed copper (RA copper) is commonly used for flex PCBs due to its improved ductility for bending applications.

Layer Count: The number of layers in a dynamic flex board is limited to minimize stress on the copper circuits. A single-layer construction is ideal, placing the copper trace close to the neutral bend axis (the area with minimal tension or compression during flexing). Two-layer boards are acceptable with a thin adhesive-less core to maintain minimal distance between the circuits and the neutral bend axis.

Stress and Strain on Circuitry

Sharp Bends and Corners: Avoid sharp bends and corners in trace routing. Gradual bends are easier on the copper traces and reduce the risk of damage.

Trace Placement: Whenever possible, keep conductors smaller than 10 mil within the neutral bend axis as they tolerate compression better than stretching.

Plated Through-Holes (PTHs): Avoid PTHs within bend areas as they can break due to stress.

Trace Orientation: Traces should run perpendicular to the bend axis to minimize stress.

Component Placement

Unsupported Pads: Component pads on the outer layers are more prone to lifting due to the flexible nature of the substrate. To prevent this, incorporate anchors or spurs encapsulated in the coverlay to provide mechanical support.

Solder Joints: Solder joints can weaken if components are placed in bending areas. For surface-mount components on the flex area, consider using solder bumps on the pads for better control over the connections. If through-hole components are necessary in a flex area, add stiffeners for support.

Overcoming Challenges

Design for Flexibility

Minimize Layer Count: Whenever possible, use a single-layer design for dynamic flex PCBs.

Gradual Bends: Design with smooth, gradual bends instead of sharp corners.

Trace Routing: Route traces perpendicular to the bend area and keep smaller traces within the neutral bend axis.

Teardrops: Utilize teardrops at the junction of pads and traces, especially when trace width changes. This helps reduce stress concentration points.

Larger Pads: Use larger component pads whenever possible for better mechanical stability.

Stiffeners: Strategically place stiffeners in areas requiring additional support for components or to manage stress on the flex area.

Material Selection

Rolled Annealed Copper: Use rolled annealed copper for its improved bendability.

Adhesive-Less Core (for 2-layer boards): If using a two-layer design, choose a thin, adhesive-less core material.

Manufacturing Considerations

Minimum Bend Radius: Clearly specify the minimum bend radius requirement in the design specifications for the manufacturer.

Component Placement: Indicate component placement restrictions in the design, especially for areas that should not have components due to flexing.

When Should You Use Flex Instead of Rigid?

Given all the challenges and extra accommodations we need to make for flex PCB design, when is it the right time to use flex PCB material as opposed to rigid PCB material?

Simply it's when your application won't allow for a standard rigid PCB solution. All of PCB design is driven by the end goal. The end goal sets the needs and requirements and rigid PCB will either meet those requirements or fall short.

In that case, flex PCB designs become the next best solution. This is the same scenario where printed wiring boards became too cumbersome for more modern applications. Now, standard PCBs, while still used everywhere, are no longer able to meet the tight physical constraints required of new, cool technology.

However, you don't need to wait to implement something in flex. Maybe you want to take advantage of fewer discrete wires and components, or opting for a lighter design, or creating a more portable version of an existing product simply because it's possible.

All these options make flex PCB a fair choice. Then at that point, you're in the realm of flex PCBs. To give you an idea of how and where flex PCBs are implemented and where you would use them, read the next section where we highlight the popular technologies that help push the boundaries of PCB design.

Applications of Flex PCBs

Flex PCBs find their application in a wide range of industries, from consumer electronics to aerospace and defense. Some notable examples include:

Wearable Devices

The flexibility of flex PCBs allows them to be integrated into form-fitting, ergonomic wearable products such as smartwatches, fitness trackers, and smart clothing.

Smartwatches



Smart watch on woman's wrist

Fitness Trackers



Fitness tracker on wrist

Smart Clothing



Sensors underneath white shirt

If it weren't for flexible PCBs, these devices shown above would not be as wearable. They would be clunky, cumbersome to work with and be worn for only short periods of time if using rigid PCBs.

Handheld Electronics

Flex circuits enable the compact and efficient design of smartphones, tablets, cameras and other portable electronic devices, where space and weight are critical factors.

Smartphones

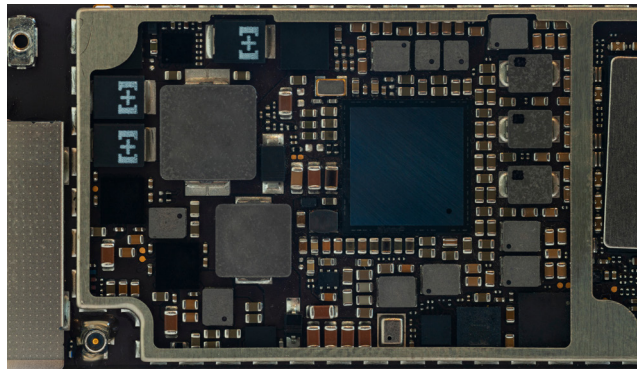

Smartphone components, circuit board from the modern mobile phone

Tablets



Tablet used by software engineer

Cameras

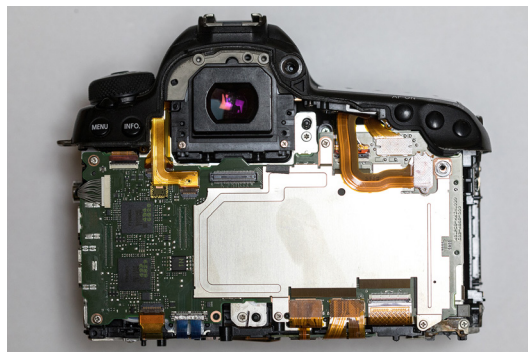

The inside of a DSLR camera

Notice how the flex PCBs act as connections among rigid PCBs. As mentioned earlier in the Benefits section, while flex PCBs can be expensive, some of that expense is compensated for, because they make reliable board-to-board connectors compared to cables.

Using cables and standard connectors in rigid PCBs to achieve the same product design goals would simply be impossible. Rigid makes the product larger and less portable.

Automotive Electronics

Flex PCBs are widely used in automotive applications, such as dashboard displays, seat controls, and sensor modules, where they must withstand vibrations and other harsh environmental conditions.



Car Dashpanel Display

Medical Equipment

Flex circuits are essential in the design of medical devices, from surgical tools to diagnostic equipment, where their flexibility and durability are crucial.

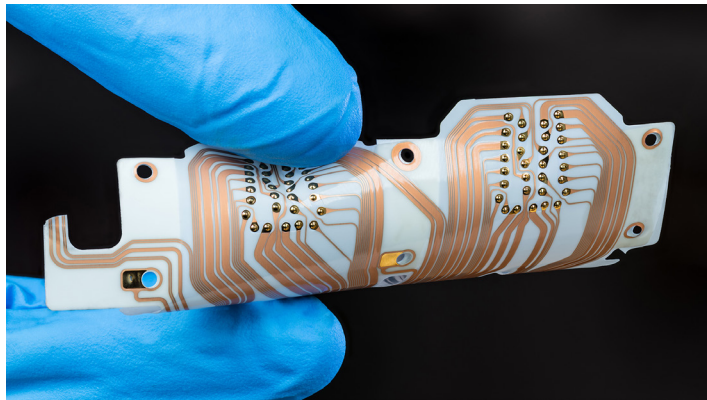

Flex PCBs possibly used in medical devices

Aerospace and Defense

In the aerospace and defense sectors, flex PCBs are valued for their ability to withstand extreme temperatures, shock, and vibration, making them ideal for use in satellites, missiles, and other high-performance applications.



Hubble Space Telescope in orbit above earth

The Future of Flex PCB Design Data

The industry is steadily moving towards more advanced design data formats like IPC-2581. This shift allows for more complex and robust Flex PCB designs to be accurately manufactured. By using these formats, you can ensure clear communication with your manufacturer, leading to a successful and efficient production process.

By following these steps and leveraging the powerful features of Cadence OrCAD X, you can confidently design and create innovative, reliable, and high-performance flex PCBs that meet the demands of today's ever-evolving electronics landscape.

Conclusion

Flex PCBs have emerged as a transformative technology, enabling engineers to push the boundaries of what's possible in product design. By understanding the benefits, applications, and design process of flex PCBs, you can unlock new opportunities to create compact, efficient, and durable electronic devices that meet the needs of the modern world. Whether you're working on consumer electronics, medical devices, or aerospace applications, mastering flex PCB design can give you a competitive edge and help you deliver groundbreaking solutions.

Appendix (Useful Information)

Design Standards for Rigid-Flex PCBs

IPC-2223: This is the industry standard for the design of flexible printed boards (FPBs) and provides guidelines for material selection, electrical performance, mechanical considerations, and manufacturing processes. It's important to note that IPC-2221 addresses rigid PCBs but many of the fundamental concepts carry over.

IPC-6013: This standard specifies qualification and performance requirements for flexible printed boards. It includes details on electrical testing, mechanical testing, and environmental testing to ensure the reliability of flex PCBs in various applications.

MIL-PRF-31032: This U.S. military standard establishes performance requirements and qualification procedures for flexible and rigid-flex printed boards used in military applications. It's more stringent than IPC standards and may include additional tests and certifications.

Example Rigid-Flex Stack-Ups

Here are a few examples of commonly used stack-ups for rigid-flex PCBs:

One Layer Flex Stackups

With Soldermask



With Coverlay



With Stiffener

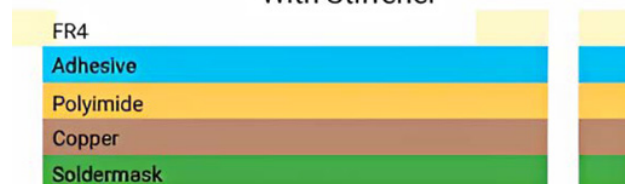

With Kapton Stiffener

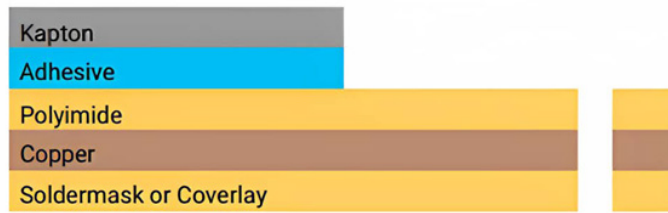

Multilayer Flex Stack-Ups

4 Layer



4 Layer With Stiffener



6 Layer with LDI LPI Soldermask

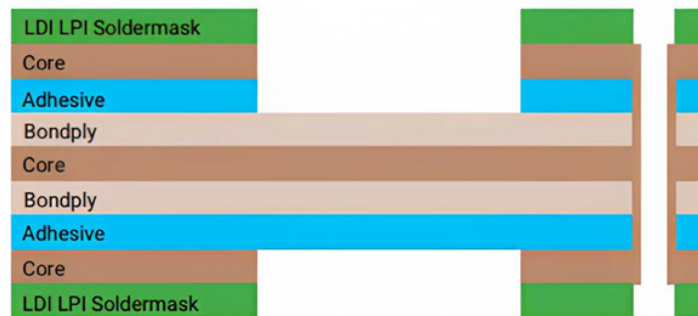

Rigid-Flex Stackups

2 Layers

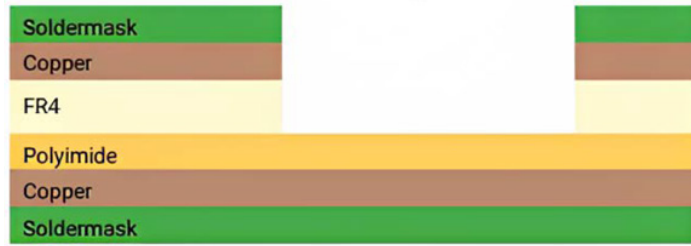

4 Layers

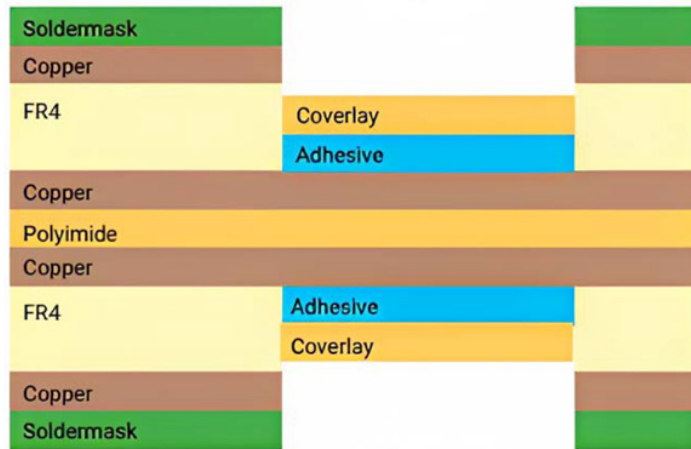

6 Layers

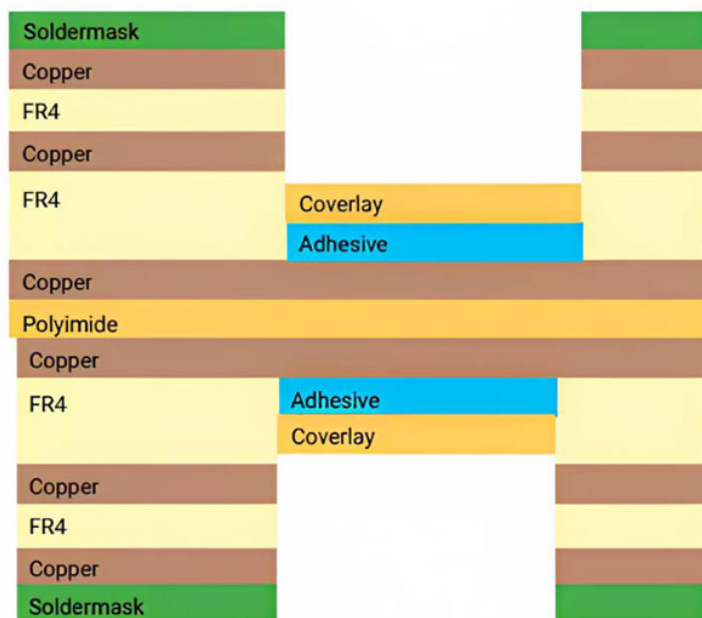

List of Terms and Materials

- ▶ **Rigid Section:** The stiff and non-bendable portion of the PCB made from FR4 or similar material.
- ▶ **Flexible Section:** The bendable portion of the PCB made from polyimide or other flexible dielectric material.
- ▶ **Flex Core:** The core layer of the flexible section, typically a thin layer of polyimide with copper traces on either side.
- ▶ **Coverlay:** A protective layer applied to the outer surfaces of the PCB to protect the copper traces from scratches and environmental factors.
- ▶ **Stiffener:** A thin piece of rigid material (FR4 or metal) added to the flexible section to provide additional support and prevent excessive bending.
- ▶ **Bend Radius:** The minimum radius at which the flexible section can bend without damaging the copper traces or delaminating the layers.
- ▶ **Hole-to-Flex Distance:** The minimum distance between a via or plated through hole and the edge of the flexible section.
- ▶ **Impedance Control:** Designing the PCB to maintain a consistent electrical impedance for signal traces to minimize signal reflections and ensure signal integrity.
- ▶ **Bookbinding Construction:** A technique used where layers of flex PCB are manufactured in progressively longer lengths around the outside bend radius. Helps reduce damage from bending, but increases cost by 30% or more.

Additional Resources

For more information on rigid-flex PCB design, visit our [resources hub](#).

The Cadence logo consists of the word "cadence" in a lowercase, sans-serif font. A red vertical line is positioned to the right of the logo.

Cadence is a pivotal leader in electronic design and computational expertise, using their Intelligent System Design Strategy to turn design concepts into reality. Cadence customers are the world's most creative and innovative companies, delivering extraordinary electronic products from chips to boards to systems in the most dynamic market applications. www.cadence.com

© 2024 Cadence Design Systems, Inc. All rights reserved worldwide. Cadence, the Cadence logo, and the other Cadence marks found at www.cadence.com/go/trademarks are trademarks or registered trademarks of Cadence Design Systems, Inc. All other trademarks are the property of their respective owners. 07/24 BS/CPG/RGD-FLX/PDF



© 2024 Cadence Design Systems, Inc.

Printed in the United States of America.

Cadence Design Systems, Inc. (Cadence), 2655 Seely Ave., San Jose, CA 95134, USA.

Open SystemC, Open SystemC Initiative, OSCI, SystemC, and SystemC Initiative are trademarks or registered trademarks of Open SystemC Initiative, Inc. in the United States and other countries and are used with permission.

Trademarks: Trademarks and service marks of Cadence Design Systems, Inc. (Cadence) contained in this document are attributed to Cadence with the appropriate symbol. For queries regarding Cadence's trademarks, contact the corporate legal department at the address shown above or call 800.862.4522.

All other trademarks are the property of their respective holders.

Restricted Permission: This publication is protected by copyright law and international treaties and contains trade secrets and proprietary information owned by Cadence. Unauthorized reproduction or distribution of this publication, or any portion of it, may result in civil and criminal penalties. Except as specified in this permission statement, this publication may not be copied, reproduced, modified, published, uploaded, posted, transmitted, or distributed in any way, without prior written permission from Cadence. Unless otherwise agreed to by Cadence in writing, this statement grants Cadence customers permission to print one (1) hard copy of this publication subject to the following conditions:

1. The publication may be used only in accordance with a written agreement between Cadence and its customer.
2. The publication may not be modified in any way.
3. Any authorized copy of the publication or portion thereof must include all original copyright, trademark, and other proprietary notices and this permission statement.
4. The information contained in this document cannot be used in the development of like products or software, whether for internal or external use, and shall not be used for the benefit of any other party, whether or not for consideration.

Disclaimer: Information in this publication is subject to change without notice and does not represent a commitment on the part of Cadence. Except as may be explicitly set forth in such agreement, Cadence does not make, and expressly disclaims, any representations or warranties as to the completeness, accuracy or usefulness of the information contained in this document. Cadence does not warrant that use of such information will not infringe any third-party rights, nor does Cadence assume any liability for damages or costs of any kind that may result from use of such information.

Cadence is committed to using respectful language in our code and communications. We are also active in the removal and replacement of inappropriate language from existing content. This product documentation may however contain material that is no longer considered appropriate but still reflects long-standing industry terminology. Such content will be addressed at a time when the related software can be updated without end-user impact.

Restricted Rights: Use, duplication, or disclosure by the Government is subject to restrictions as set forth in FAR52.227-14 and DFAR252.227-7013 et seq. or its successor.